

UBI-2590 SMBus (Part No. UBBL10) Battery Specification



For the most up to date information on this product, useful accessories, and other products visit the Ultralife Batteries website at www.ultralifebatteries.com.



2000 Technology Parkway
Newark NY 14513

Title: UBI-2590, SMBus (Part No. UBBL10) Battery Specification

Table of Contents

1.	Document Scope	3
2.	Important Nomenclature	3
3.	Battery Description	3
4.	Battery Compatibility.....	3
5.	Battery Capacity (C)	3
6.	Voltage	3
7.	Discharge Current	3
8.	Charge Instructions	4
9.	Temperature Storage	5
10.	Operational Temperature	5
11.	Capacity Testing.....	6
12.	Cycle Life Testing.....	8
13.	Shelf Life.....	9
14.	Dimensions.....	9
15.	Weight.....	9
16.	Case Material	9
17.	Case Color.....	9
18.	Label requirements.....	9
19.	Connector	10
20.	Battery Protection Circuit.....	10
21.	State of Charge Indication (SOC).....	10
22.	Chargers and Charge Control Chipsets	10
23.	Quality and Workmanship	10
24.	Shipping and Transportation Requirements.....	10
25.	Safety Requirements	10

1. Document Scope

- 1.1. This document pertains to the performance, operation of, and the physical characteristics of the UBI-2590, SMBus battery pack.
- 1.2. All information contained in this specification is targeted for single battery applications, where each section is used either in parallel or series. For applications using multiple batteries in parallel and/or series combinations, please contact Ultralife customer assistance for technical review and approval. Use of the battery in any multiple parallel and/or series combination without Ultralife technical approval will void any and all warranties of said product. Ultralife does not suggest that this product be used in multiple parallel or series configurations without additional safety and circuit protection devices, and failure to add said devices will result in assumed liability.

2. Important Nomenclature

- 2.1. Ambient Conditions: 25°C ±3°C
- 2.2. C Rate: The rate at which 100% capacity is obtained under ambient conditions in 1 hour of constant current discharge

3. Battery Description

- 3.1. The UBI-2590, SMBus battery pack was originally designed as a rechargeable power source for several military communication devices. The pack consists of two 14.4v batteries. The device in which the battery is used determines whether the battery is used in series (33v) mode or parallel (16.5v).
- 3.2. Typical Uses: AN/PRC-104, AN/PRC-119 (SINCGARS), KY-57 Radios.
- 3.3. The UBI-2590, SMBus battery employs ULBI's SmartCircuit[®] technology by providing [SMBus v1.1](#) smart battery tools via the SBD v1.0 dataset.

4. Battery Compatibility

- 4.1. Rechargeable Batteries: BB-2590, BB-390A/U, BB-590/U, BB-690/U, BT-2590, MAI-2590, MRC-2590, UBI-2590 (UBBL02).
- 4.2. Primary Batteries: BA-5390A/U, BA-5590/U, BA-5390/U, BA-3590/U

5. Battery Capacity (C)

- 5.1. 6.8 Ah in 30 volt mode (Pack A and Pack B Connected in Series)
- 5.2. 13.6 Ah in 15 volt mode (Pack A and Pack B connected in Parallel)

6. Voltage

- 6.1. Max Voltage: 16.5 per section, 33.0 when connected in series
- 6.2. Nominal Voltage: 14.4 per section
- 6.3. Min Voltage: 10.0 per section

7. Discharge Current

- 7.1. Recommended Continuous Discharge Current: 8A in 16.5v mode or 4A in 33v mode.
- 7.2. Maximum Continuous Discharge Current: 12A in 16.5v mode or 6A in 33v mode.
- 7.3. Pulse Discharge
 - 7.3.1. Max Pulse Currents: 36A for 5 seconds in 16.5v mode, 18A for 5 seconds in 33v mode
 - 7.3.2. Pulse current and duty cycle will cause performance to vary greatly, especially at temperature extremes.
- 7.4. **NOTE:** The continuous use of the battery at or near max discharge capability, especially at elevated temperatures, will cause reset-able internal thermal protection devices to activate. See Figure 1.

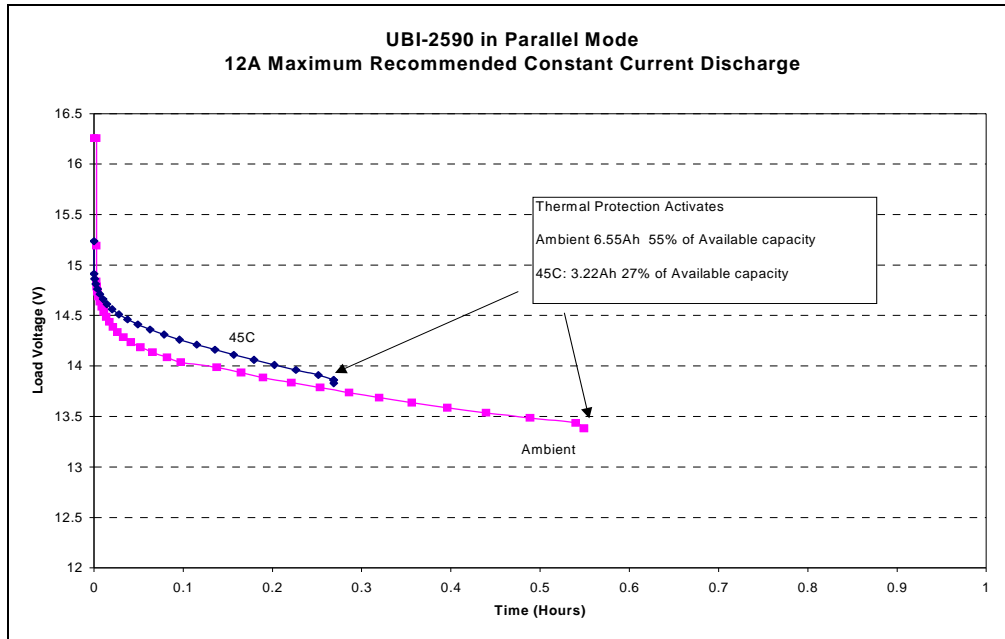

Figure 1

7.5. Battery ratings based upon C/5 (1.36A) discharge current under ambient conditions.

8. Charge Instructions

8.1. Recommended Charge: Charge each section at Constant Voltage at 16.5 volts, current limited to 3A for 3 hours or until current reduces below 300mA. See Figure 2 for a typical graph.

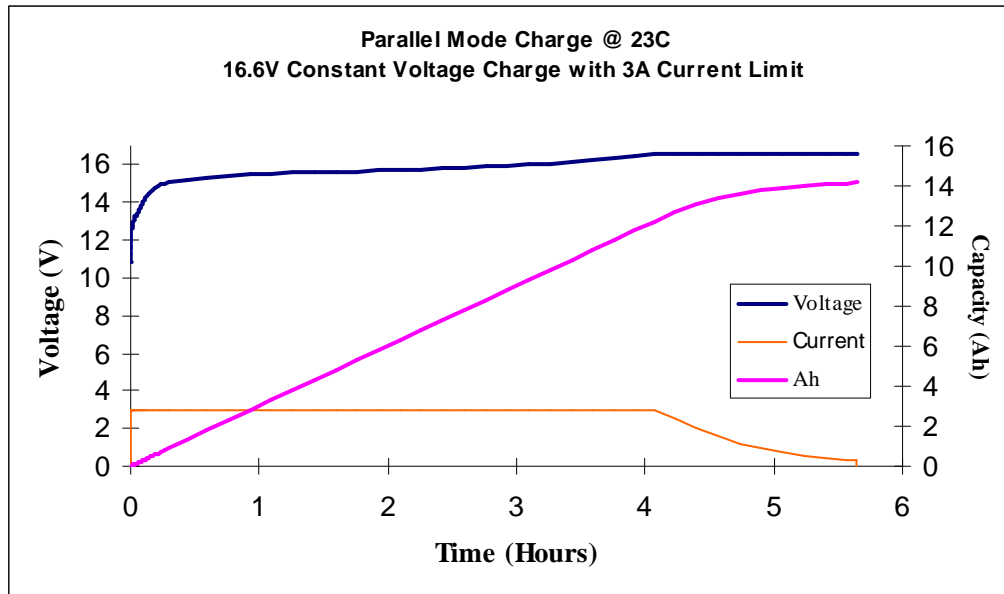

Figure 2

- 8.2. Maximum charge rate: 6A or less.
- 8.3. Each section should be charged fully before use of the battery, especially when used in series mode, to keep each section of the pack in balance and prevent over discharge of one section.
- 8.4. NOTE: Charge times will vary based on charge current used, lower currents result in longer times
- 8.5. Battery sections can be charged in parallel, however charge times will increase. See figure 3 for a typical graph.

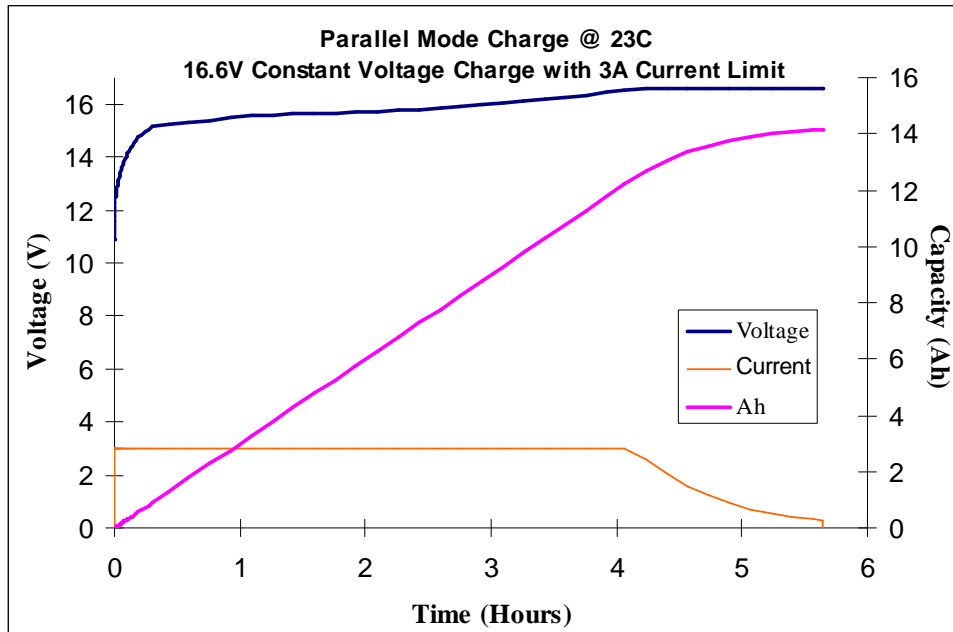

Figure 3

9. Temperature Storage

- 9.1. Storage between -32°C and 60°C
- 9.2. Store battery between 0°C and 45°C for optimum performance.
- 9.3. Storage between 45°C and 60°C is possible, with product performance losses.
- 9.4. A temporary thermal disabling device will operate if internal pack temperature reaches 70±5°C.
- 9.5. Storage above 91°C or an extended storage at 68°C will cause a permanent disabling device to activate.
- 9.6. Do not store below 25% state of charge.

10. Operational Temperature

- 10.1. Operational between -32°C and 60°C
- 10.2. Operate battery between 10°C and 45°C for specified performance characteristics.
- 10.3. Operation outside of the specified window will result in lower product performance dependent on application usage.
- 10.4. A temporary thermal disabling device will operate if internal pack temperature reaches 70±5°C.
- 10.5. Operation above 91°C or an extended storage at 68°C will cause a permanent disabling device to activate.

11. Capacity Testing

11.1. Rated capacity is specified as the C/5 discharge rate under ambient discharge conditions, when previously completing charge at ambient conditions within 1 hour of discharge per the specified charge regime.

11.2. Parallel Mode Ambient Constant Current Discharges Voltage –v- Time (Figure 4)

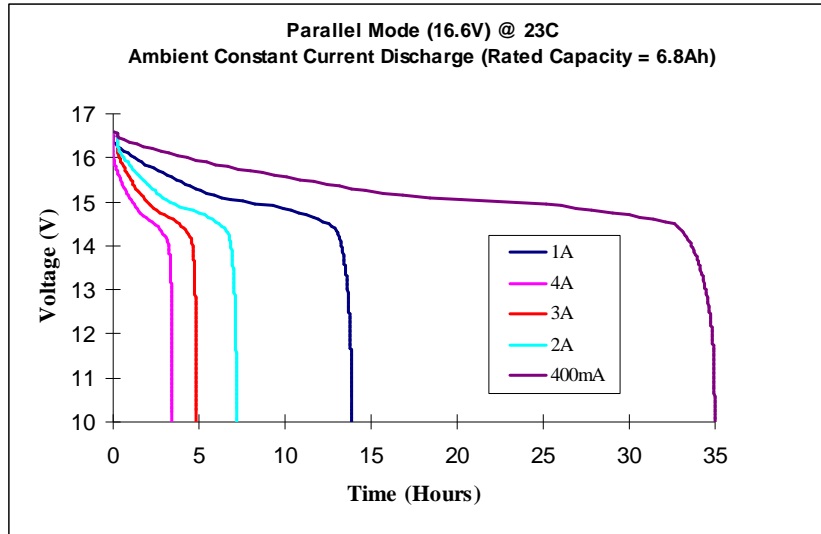

Figure 4

11.3. Parallel Mode Ambient Constant Current Discharges Voltage –v- Rated Capacity (Figure 5)

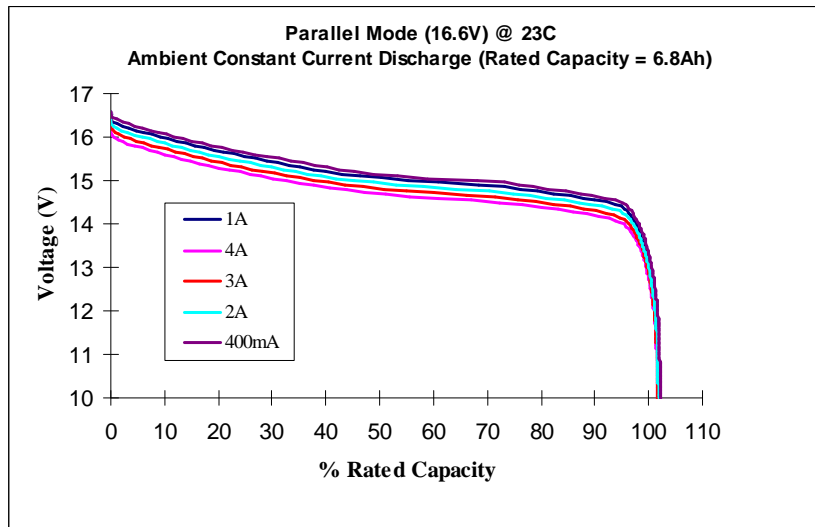

Figure 5

11.4. Series Mode Ambient Constant Current Discharges Voltage –v- Time (Figures 6)

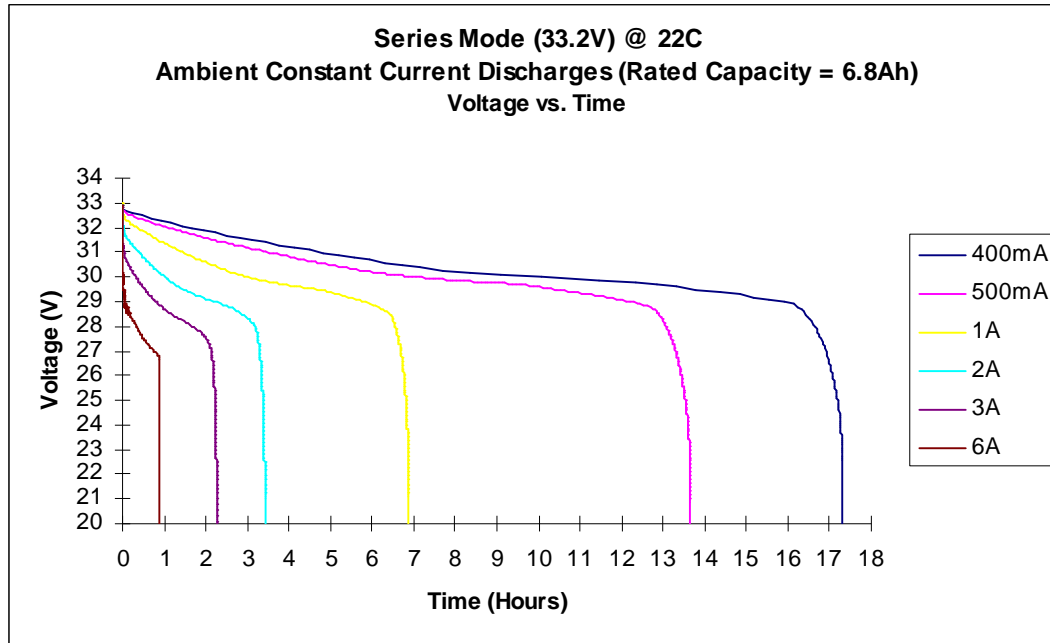

Figure 6

11.5. Series Mode Ambient Constant Current Discharges Voltage –v- Rated Capacity (Figure 7)

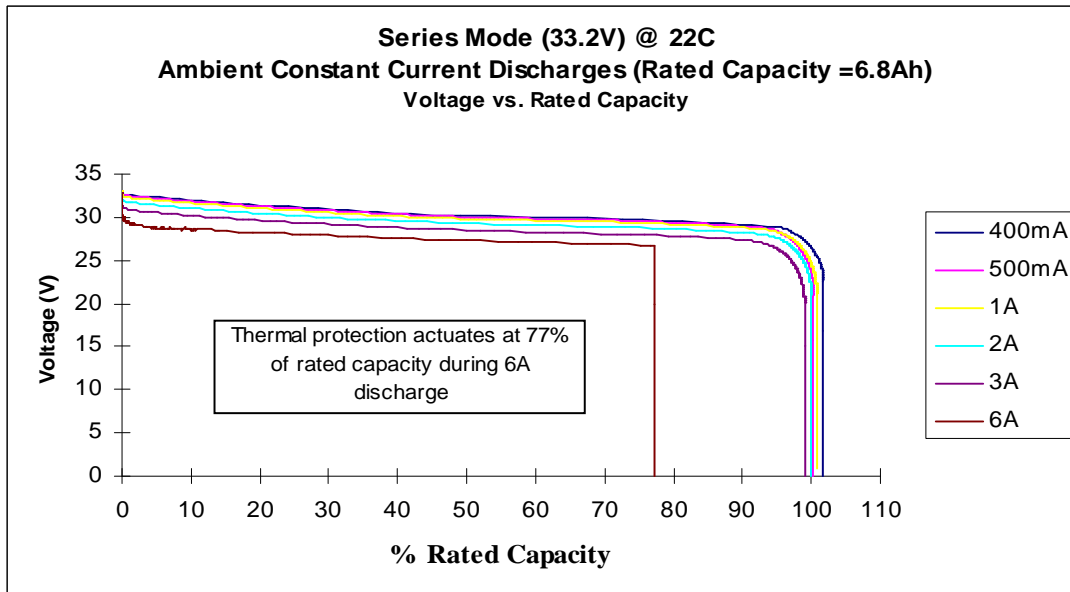

Figure 7

12. Cycle Life Testing

- 12.1. The pack will obtain 300 cycles at greater than 80% rated capacity at recommended charge and C/5 discharge rates under ambient conditions.
- 12.2. A graph of sections cycled independently under ambient temperatures. A constant current discharge of 3A was used until the voltage reaches 10.0v. This graph illustrates that both sections of the pack are capable of supplying over 80% of rated capacity at 300 cycles. See Figure 8.

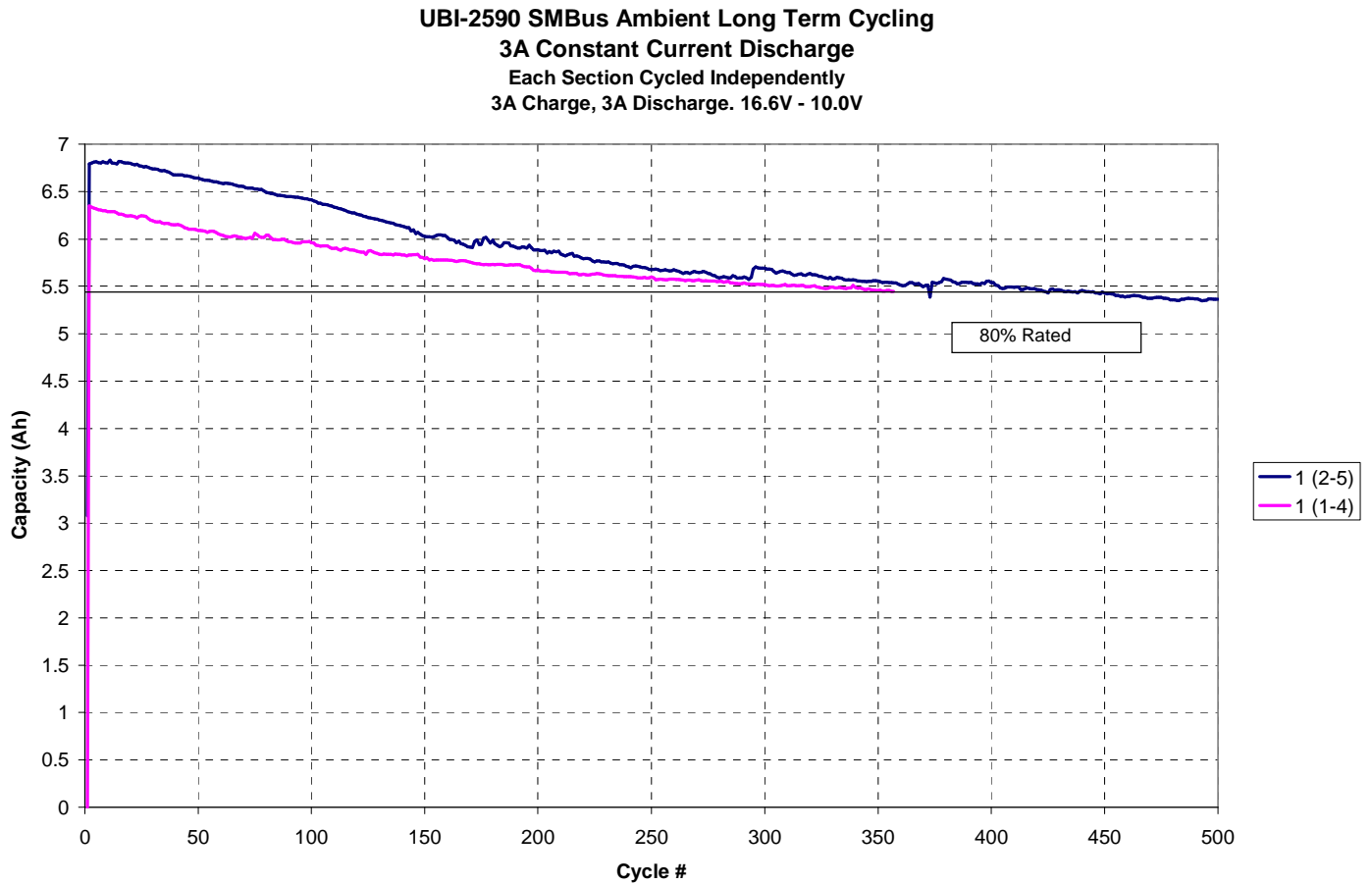

Figure 8

13. Shelf Life

- 13.1. Self-discharge due to cells is typically less than 2% per month.
- 13.2. The battery pack should retain greater than 95% of the initial capacity when stored for 1 year under ambient conditions when tested per the capacity test in section 11.
- 13.3. The battery pack should retain greater than 90% of the initial capacity when stored for 1 year at temperatures above ambient and below 45°C when tested per the capacity test in section 11
- 13.4. The battery should retain greater than 85% of the initial of the initial capacity when stored for 6 months at temperatures above 45°C and below 60°C when tested per the capacity test in section 11.
- 13.5. The PCB with State of Charge Indication LCD, when in sleep mode (no current flow for more than 2 seconds), will consume current at an average of 0.35 ma or a capacity of 8.4mAh per day. This is in addition to the cell self discharge. This occurs for each pack section independently.
- 13.6. The PCB with State of Charge Indication LCD, when in awake mode (current flow), will consume current at an average of 0.8 mA or a capacity of 19.2 mAh per day. This is in addition to the cell self discharge. This occurs for each pack section independently.

14. Dimensions

- 14.1. 62.5 mm x 112.5 mm x 127.0 mm (2.48" x 4.43" x 5.0")

15. Weight

- 15.1. 1440 g maximum

16. Case Material

- 16.1. GE Noryl 190X

17. Case Color

- 17.1. Lusterless Black

18. Label requirements

- 18.1. The label will include manufacturer, location, and country of origin.
- 18.2. Safety Information and Warnings:
 - 18.2.1. CHARGE INSTRUCTIONS: Charge each section at 16.5v (16.8v Max) Constant Voltage with Maximum Current of 3A. Battery temperature should be between 40°F (5°C) and 100°F (38°C) during charge. Lower temperature charging is permitted but run times will be lower.
 - 18.2.2. WARNING/ STORAGE: Do not store below 25% state of charge. Do not store above 140°F (60°C), Crush, Mutilate, Reverse Polarity, Disassemble, or Dispose of in Fire.
- 18.3. The label shall be legible and free from visible defects such as wrinkles and cracks.
- 18.4. The battery pack will be serialized to maintain trace ability.
- 18.5. The connector contacts will be clearly labeled for polarity.

19. Connector

- 19.1. Floating type per U.S. Army drawing number: SC-C-179495.
19.2. Connection polarity and SMBus contact details:

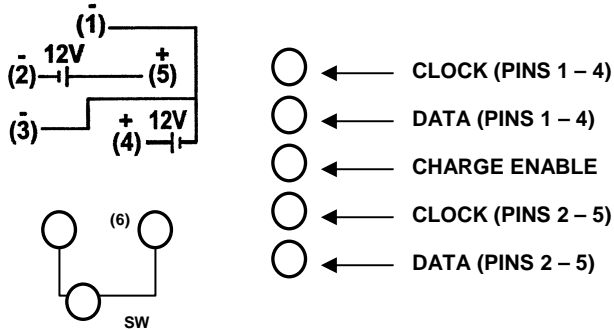
**20. Battery Protection Circuit**

- 20.1. Prevent each section from exceeding 17.4v
20.2. Assure each section min voltage above 11v
20.3. All cells prevented from exceeding 4.35v
20.4. All cells prevented from discharge below 2.75v
20.5. Over current protection setting: 18.4A
20.6. Typical Discharge current is 4A and below
20.7. Prevent external short circuit of the pack (Current in excess of 18A per section)

21. State of Charge Indication (SOC)

- 21.1. The battery contains two 5-segment LCD displays to provide state of charge for each section of the battery pack, with each segment representing 20% of total capacity.
21.2. When the capacity is below 5%, the last remaining bar on the display will begin to flash as a warning of low capacity.
21.3. The state of charge chipset requires a complete discharge followed by a complete charge to remain accurate.

22. Chargers and Charge Control Chipsets

- 22.1. Only use approved chargers or chipsets that operate within specified charge profile requirements
22.2. Lower charge currents are acceptable, but result in increased charge time requirements.

23. Quality and Workmanship

- 23.1. The battery case and connector will be free of visible scratches, cracks, and or damage.

24. Shipping and Transportation Requirements

- 24.1. The battery pack will be shipped in a state of charge greater than 50% and less than 70%, to allow storage in sleep mode (no current flow for more than 2 seconds) for up to 1 year without recharging.
24.2. UN T1 – T8 testing completed and passed.
24.3. Class 9 regulation for shipment.

25. Safety Requirements

- 25.1. Only specified connectors and cables should be used to connect with battery pack, such as Ultralife part number CA0002, CA0006, CA0007.
25.2. Do not store above 60°C (140°F), Crush, Mutilate, Reverse Polarity, Disassemble, or Dispose of in Fire.